

# APACHE LEGACY CONE CRUSHER

**MODEL : L SERIES LEGACY CONE CRUSHER— STANDARD & FINE HEAD CONFIGURATION**

**LS3.0 / LS4.25 / LS5.5 / LS7.0 / LS SHD5.5 / LS SHD7.0**

**Mainframe** - Cast Steel Mainframe with machined seat surfaces.

**Bowl Assembly** - Fabricated Steel Bowl Assembly with replaceable bowl ring gear

**Head Assembly** – Machined Steel Head with main-shaft. Shaft-in-Head design (pressed fit)

**Bearings** - Machined bronze bushings exhibit higher tolerance to heat and vibration than roller bearings, and are lower cost to replace when required.

**Adjustment** - Bowl Ring Gear Adjust System (Hydraulic Powered).

**Tramp System** - Dual Acting Tramp Cylinder Relief System with remote nitrogen charged bladders

**Hydraulic Lock Cylinders with Cavity Clear Function**

**HPU** – Hydraulic Power Unit with oil reservoir, pump, gauges, filter & TEFC Electric Motor, all required lines & fittings.

**LSU** – Lubrication System Unit with oil reservoir, pump, filter & TEFC Electric Motor, radiator and fan cooling system with TEFC Electric Motor, and all required piping and connections.

**Integrated Safety Switches** – Oil flow and Oil Temperature Switches integrated into control system to shut down cone in the event of overheating or loss of oil pressure.

**Drive Package** – TEFC 1200 RPM Crusher Duty Electric Motor, drive and driven sheaves, bushings and v-belts.

**Paint** – Primed and Painted Charcoal Grey Machinery Enamel with Red & White Decals

**Will fit replacement for domestic 3' - 7' XHD Machines**

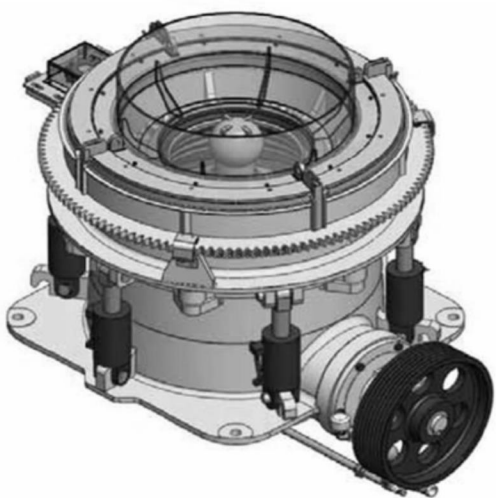

SALES@APACHEIRONWORKS.COM • WWW.APACHEIRONWORKS.COM

MINING IS TOUGH • APACHE IS TOUGHER • BUILT MINER STRONG